

Digi - SENSE®

Thermocouple Thermometer Models

60010-00 (Type J)

60010-10 (Type K)

60010-20 (Type T)



OAKTON®

**EUTECH
INSTRUMENTS**

Technology Made Easy...

68X309905 Rev 1 04/04

ISO 9001
SUPPLIER CERTIFIED

TABLE OF CONTENTS

1.	INTRODUCTION	4
2.	SAFETY PRECAUTIONS	6
3.	SPECIFICATIONS	7
4.	BATTERY INSTALLATION AND REPLACEMENT	10
5.	SELF TEST	12
6.	CONNECTING A THERMOCOUPLE	12
7.	SELECTING TEMPERATURE SCALE	16
8.	HOLD FUNCTION	17
9.	CALIBRATION	17
10.	CANCELING A FIELD CALIBRATION	18
11.	FIELD CALIBRATION LOCKOUT AND RE-ENABLE	19
12.	LOCKOUT PROCEDURE	19
13.	RE-ENABLE PROCEDURE	20
14.	MAINTENANCE	20
15.	CLEANING	21
16.	BATTERIES	21
17.	ACCESSORIES	22
18.	SERVICE	24
19.	WARRANTY	25
20.	PRODUCT RETURN	25

1. INTRODUCTION

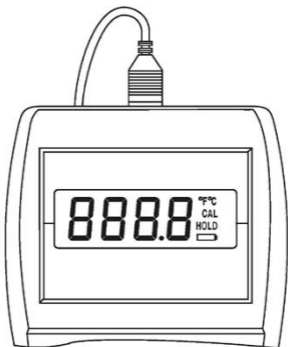

This versatile hand-held instrument provides highly accurate temperature measurements. The instrument is designed for easy operation and includes

the following features:

- Operator selection of Celsius or Fahrenheit scale
- Resolution of 0.1° from -99.9 to 299.9°
- Four-digit LCD
- Hold feature for temporarily retaining a reading
- Field calibration capability

- Low battery warning
 - Built-in tilt stand for easy hands-free operation
- Two blade female ANSI mini-connector input
- Operates with a wide selection of probes 2

2. SAFETY PRECAUTIONS

WARNING: THIS INSTRUMENT IS DESIGNED TO ACCEPT LOW LEVEL SIGNALS SUPPLIED BY STANDARD THERMOCOUPLES. UNDER NO CIRCUMSTANCES SHOULD THE INPUT VOLTAGE EXCEED THE SPECIFIED 50V RMS.

CAUTION: DO NOT USE OR STORE THIS INSTRUMENT IN MICROWAVE OVENS OR ANY ABNORMALLY HOT OR COLD AREAS.

CAUTION: WEAK BATTERIES SHOULD NOT BE LEFT IN THE INSTRUMENT. DEAD BATTERIES CAN LEAK AND CAUSE DAMAGE TO UNIT.

DANGER: VOLTAGES PRESENT AT THE THERMOCOUPLE MAY ALSO BE PRESENT AT THE BATTERY TERMINALS. ALWAYS DISCONNECT THE THERMOCOUPLE WHEN CHANGING BATTERIES.

WARNING: TO PREVENT IGNITION OF A HAZARDOUS ATMOSPHERE, BATTERIES MUST ONLY BE CHANGED IN AN AREA KNOWN TO BE NON-HAZARDOUS.

3. SPECIFICATIONS

THERMOCOUPLE PROBES

<u>Type</u>	<u>Temperature range</u>
Type J	-200°C to 1000°C (-328°F to 1832°F)
Type K	-250°C to 1372°C (-418°F to 2501°F)
Type T	-250°C to 400°C (-418°F to 752°F)

Out of range display: - - - -

Resolution

0.1°/1° autoranging, 0.1° from -99.9° to 299.9°, 1° outside this range.

Accuracy

> -99.9°: +(0.2% of reading +0.5°C)
+(0.2% of reading +0.9°F)
< -99.9°: +(0.25% of reading, +1°C)
+(0.25% of reading +2°F)

Display

4-digit LCD with 0.5 in high numerals.

Display update rate

0.6 sec per update.

Input

One thermocouple with ANSI connector.

Input Protection

50V rms

Battery

Two AA, 1.5V alkaline ANSI-L40, IEC-LR6.

Battery Life: 750 hours continuous, typical.

Low battery indication

Battery Symbol on when 8 to 10 hours of battery life remains.

Battery symbol blinking: replace battery

Operating Conditions

Stated accuracy:

18°C to 28°C (64°F to 82°F)

Useful range:

0°C to 40°C (32°F to 104°F)

Storage:

-40°C to 65°C (-40°F to 149°F)

Humidity (non-condensing):

10% to 90% 4

Dimensions

3 cm D x 8.4 cm W x 15.8 cm H

(1.2 in x 3.3 in x 6.2 in)

Weight with batteries

227 grams (8 ounces)

Ingress protection

Meets IEC-529 IP-54 for dust and water resistant enclosures.

Intrinsic safety

This product is energy limited for intrinsically safe operation in hydrogen atmospheres per Class I, Division 1, Groups A, B, C and D hazardous(classified) locations for UL per UL913 and CSA per C22.2 No. 0-M1982 and No. 157-M1987. Maximum surface temperature: 135°C (T4); UL file No. E182612 (1997).

Electromagnetic Compatibility

(For CE Mark) EN61326-1/1A: 1998
(EU EMC Directive)

4. BATTERY INSTALLATION AND REPLACEMENT

If battery indicator turns on, battery life is approximately 8 to 10 hours. The battery indicator will start blinking with less than 1 hour of life remaining.

Selected settings are stored in memory and will remain in memory even after power is turned off, or while batteries are being replaced.

1. Before changing battery, turn instrument off and disconnect thermocouple.
2. Loosen screw and lift battery cover off back of case.
3. Remove the two AA batteries.
4. Insert two new batteries observing polarity.
5. Install cover and tighten screw.

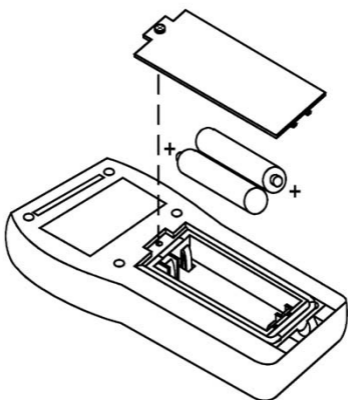

CAUTION: WEAK BATTERIES SHOULD NOT BE LEFT IN THE INSTRUMENT. DEAD BATTERIES CAN LEAK AND CAUSE DAMAGE TO UNIT.

DANGER: VOLTAGES PRESENT AT THE THERMOCOUPLE MAY ALSO BE PRESENT AT THE BATTERY TERMINALS. ALWAYS DISCONNECT THE THERMOCOUPLE WHEN CHANGING BATTERIES.

WARNING: TO PREVENT IGNITION OF A HAZARDOUS ATMOSPHERE, BATTERIES MUST ONLY BE CHANGED IN AN AREA KNOWN TO BE NON-HAZARDOUS.

5. SELF TEST

Press the ON/OFF key. The thermometer performs a self-test and all display digits and indicators, as shown below, should remain on for approximately one second.

6. CONNECTING A THERMOCOUPLE

Use the correct thermocouple type for your instrument. Using an incorrect thermocouple type will result in erroneous readings. Thermocouples are colour coded by type using the North American ANSI Color Code as follows:

<u>TYPE</u>	<u>COLOR</u>
J	Black
K	Yellow
T	Blue

Thermocouple connectors have one wide blade and one narrow blade. Do not force connector in backwards. Connect thermocouple to receptacle at top of instrument as shown in the following illustration.

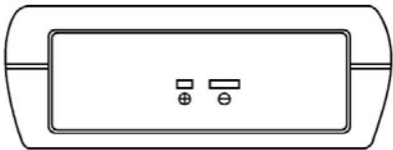

Thermocouple wiring polarity must be correct. If readings decrease as the temperature increases, the thermocouple wires may be reversed. The red wire is negative for thermocouple wires manufactured in North America.

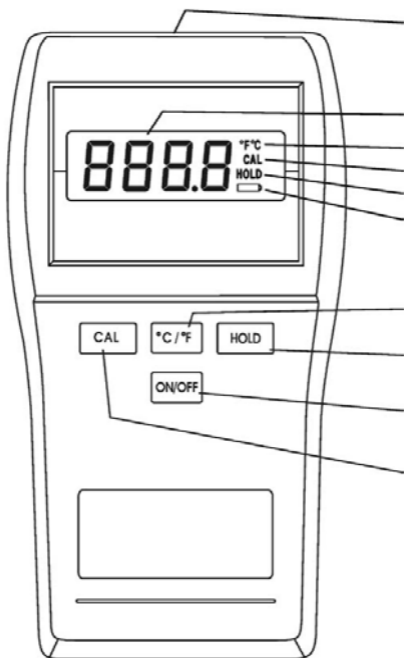

-
- Temperature display
 - Celsius or Fahrenheit
 - Field Calibration is active
 - Hold indicator
 - Low Battery Warning
 - Press to select either °F or °C
 - Press to freeze current reading in display
 - Press to turn on or turn off
 - For automatic Field Calibration (See Field Calibration section of manual).

If a thermocouple is not connected or if the thermocouple is defective, the display will indicate OPEn.

Thermocouples are sensitive at the tip or measuring junction. When taking measurements, allow time for the reading to stabilize. Multiplying the time constant of the probe by 5 will give you the approximate time required.

7. SELECTING TEMPERATURE SCALE

Select °C or °F by pressing the °C/°F key. Each time the key is pressed the temperature scale will switch. Switching between °C and °F can be done at any time during operation.

Each time you turn the instrument on, it will power up with the same settings that were set when the unit was last turned off.

8. HOLD FUNCTION

Press the HOLD key to retain the reading on the display. Press the HOLD key again for normal operation.

9. CALIBRATION

The thermometer is factory calibrated and does not require calibration before use. The CAL function allows single point calibration of the thermometer, at 0°C (32°F) to compensate for thermocouple off-set error. It is not necessary to perform a field calibration to obtain specified meter accuracy. Use the field calibration feature to improve thermometer/probe accuracy or to compensate for thermocouple drift.

1. Pack sensing end of probe in a container tightly packed with crushed ice and filled with distilled water. Allow temperature to stabilize.
2. Press and hold the CAL key for 5 seconds to enter the calibration mode, the CAL annunciator on the display starts blinking. Release the CALkey.
3. If the measured temperature is from -10°C to 10°C (14 to 50°F), when the

temperature reading is stable, press the CAL key.

The CAL indicator will stop blinking and the reading will be set to 0°C (32°F). The CAL indicator will remain turned on, indicating a field calibration is active.

If “Err” is displayed, either the displayed reading is outside the above limits or the batteries are weak.

10. CANCELING A FIELD CALIBRATION

1. Turn the thermometer off.
2. Hold the CAL key down while pressing the ON/OFF key.

The field calibration is canceled and the thermometer reverts to the default factory calibration. The CAL annunciator is now turned off.

11. FIELD CALIBRATION LOCKOUT AND RE-ENABLE

The calibration lockout feature prevents any field calibration changes. The lockout remains in effect until a lockout re-enable has been performed. Use the following procedures to lockout or re-enable the field calibration operation.

12. LOCKOUT PROCEDURE

1. Turn the thermometer off.
2. Simultaneously press and hold the CAL and the °C/°F keys down and momentarily press the ON/OFF key. Continue to hold the CAL and °C/°F keys for at least 5 seconds.

13. RE-ENABLE PROCEDURE

1. Turn the thermometer off.
2. Simultaneously press and hold the HOLD and the CAL keys down and momentarily press the ON/OFF key. Continue to hold the HOLD and CAL keys until the display blanks.

14. MAINTENANCE

Properly used, the thermometer should maintain calibration indefinitely and not require service other than occasional cleaning of the housing and changing of the batteries.

15. CLEANING

WARNING:

TO PREVENT IGNITION OF A HAZARDOUS ATMOSPHERE BY ELECTROSTATIC DISCHARGE, CLEAN WITH DAMP CLOTH.

Do not clean with abrasives or solvents. Use mild detergents, never immerse nor use excessive fluid.

16. BATTERIES

If there is no display when the thermometer is turned on, check condition of the two AA batteries. Also check that the battery terminals are clean and batteries are properly installed. If replacement is necessary, refer to the BATTERY INSTALLATION AND REPLACEMENT section for replacement procedure.

17. ACCESSORIES

Replacement Meter and Meter Accessories

Item	Ordering Code
Type J	60010-00
Type K	60010-10
Type T	60010-20
Soft carrying case	08520-05
Replacement AA batteries, pack of 4	09376-01
Certificate of Calibration	Call for part number Traceable to NIST

General purpose probe (immersion Into liquids), type J	EC-TPGLPJ-01M/ 08517-55
Penetration probe (meat, semi-soft Materials), type J	EC-TPPENJ-01M/ 08517-65
Surface probe (direct contact on Hot surfaces), type J	EC-TPSURJ-01M/ 08517-60
Clip-on probe (surface contacts-Electronics), type J	EC-TPCLPJ-01M/ 08469-00
General purpose probe (immersion Into liquids), type K	EC-TPGLPK-01M/ 08516-55
Penetration probe (meat, semi-soft Materials), type K	EC-TPPENK-01M/ 08516-65
Surface probe (direct contact on Hot surfaces), type K	EC-TPSURK-01M/ 08516-60
Clip-on probe (surface contacts-Electronics), type K	EC-TPCLPK-01M / 08469-02

18. SERVICE

WARNING

SUBSTITUTION OF COMPONENTS
MAY IMPAIR INTRINSIC SAFETY.

There are no internal adjustments or
user replaceable parts.

If “Err” followed by the numbers 1
through 9 is displayed (see example
below) return unit for service. Note that
“Err” alone may be displayed during
improper field calibration.

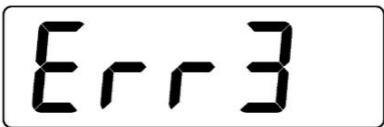

Note: Serial number label is located
inside battery compartment.

19. WARRANTY

The Manufacturer warrants this product to be free from significant deviations from published specifications for a period of **three** years. If repair or adjustment is necessary within the warranty period, the problem will be corrected at no charge if it is not due to misuse or abuse on your part as determined by the Manufacturer. Repair costs outside the warranty period, or those resulting from product misuse or abuse, may be invoiced to you.

20. PRODUCT RETURN

To limit charges and delays, contact the seller or Manufacturer for authorization and shipping instructions before returning the product, either within or outside of the warranty period. When returning the product, please state the reason for the return. For your protection, pack the product carefully and insure it against possible damage or loss. Any damages resulting from improper packaging are your responsibility.

NOTES

TECHNICAL ASSISTANCE

If you have any questions about the use of this product, contact the Manufacturer or authorized seller.

Trademarks bearing the ® symbol in this publication are registered in the U.S. and in other countries.

For more information on Eutech Instruments/ OAKTON Instruments' products, contact your nearest distributor or visit our web site listed below:

Eutech Instruments Pte Ltd

Blk 55 Ayer Rajah Crescent

#04-16 Singapore 139949

Tel: (65) 6778 6876

Fax: (65) 6773 0836

Website: www.eutechinst.com

Email: marketing@eutechinst.com

OAKTON Instruments

P.O. Box 5136

Vernon Hills, IL 60061, USA

Tel (in U.S.): 888-462-5866

Tel (outside U.S.) 1-847-549-7600

Website: www.4oakton.com

E-mail: info@oakton.com

Fax: (1) 847-247-2984

Distributed by: